

NITRO-SLG USB Module

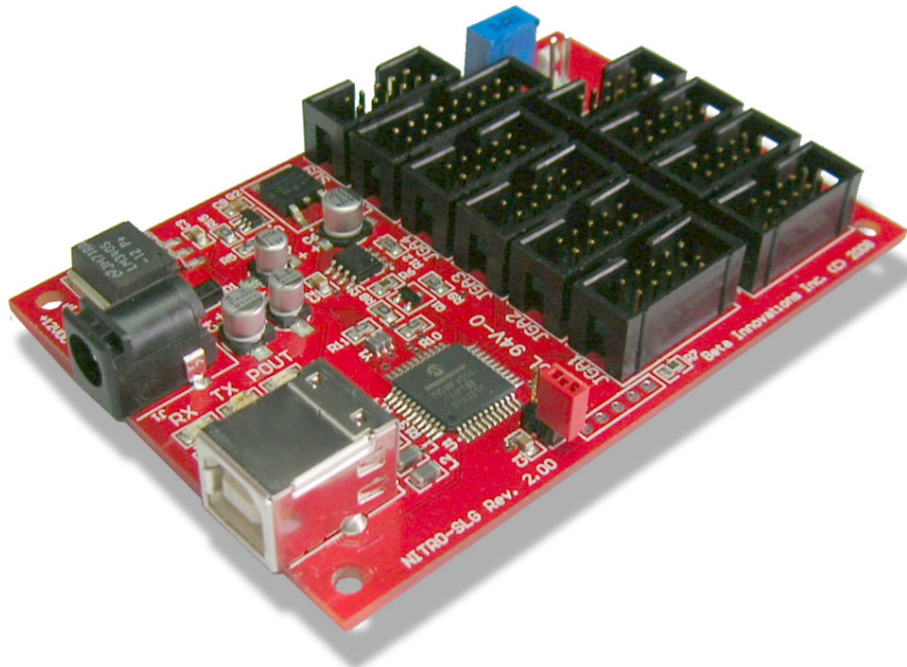

Product ID. : NITRO-SLG
Rev. : 2.00
Date : May 15, 2008
Firmware Rev. : 1.11

Table of Contents

NITRO-SLG Expansion Card	3
Main Features	4
Introduction	5
Flash Loader Mode : JP1	6
RESET Jumper JP1	6
Connecting a Gear Indicator Display	7
Common Cathode Display	7
Common Anode Display	8
Connecting an LCD Display	9
Connecting Air-Core Movements	10
Calibration Procedure	10
Connecting Shift Light Indicator	11
Hardware Specifications	12
Device Status LEDs	12
Mechanical Specifications	13

NITRO-SLG Expansion Card

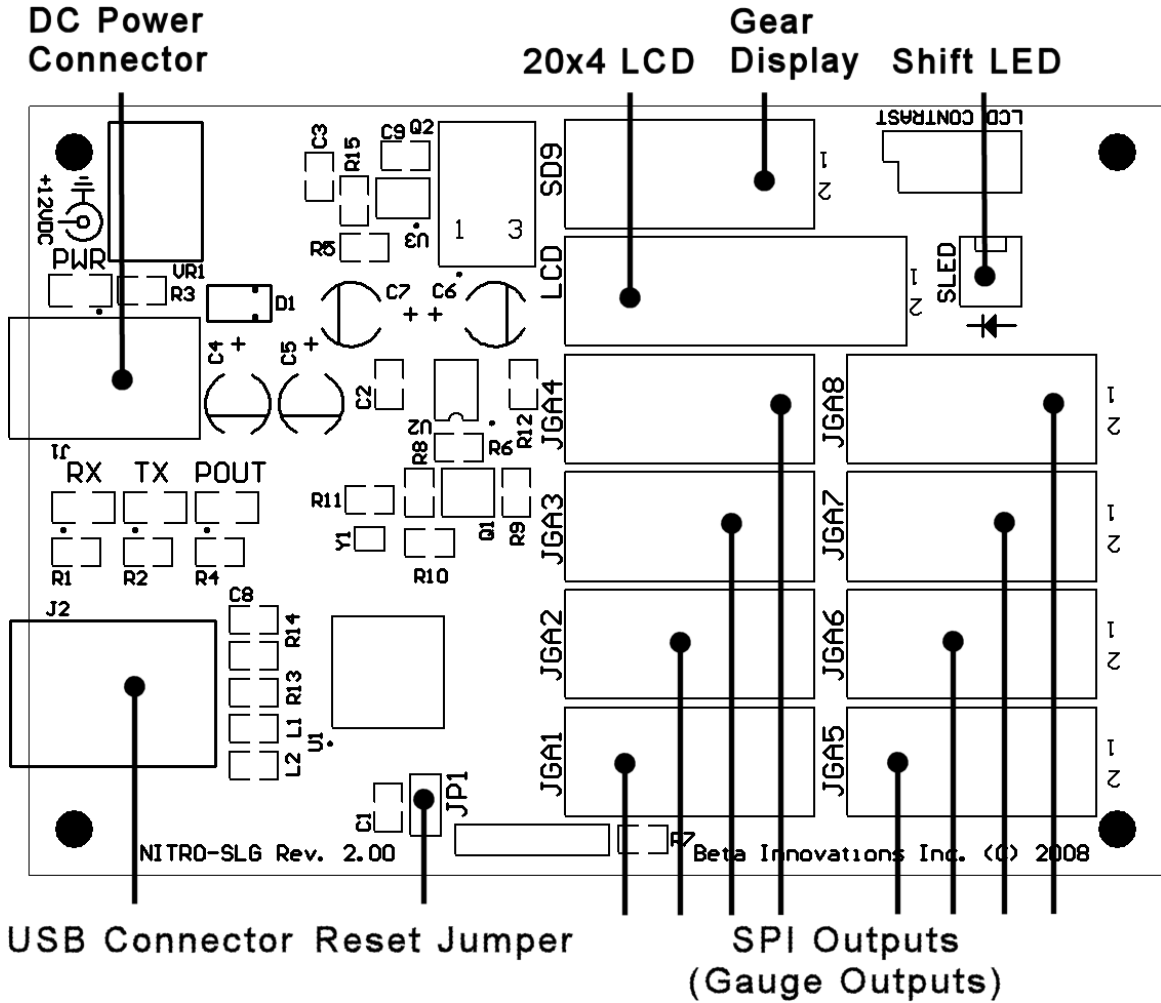

Main Features

- **Easy installation**

The NITRO-SLG module is a Full Speed USB HID compliant device, which employs default drivers supplied by most OS and self powered from a 2.1mm AC adapter.

- **SPI Output**

Supports industry standard 10-bit wide SPI (Serial Peripheral Interface) capable of controlling Air-Core Movement drivers or other compatible peripherals, such as the LBG10-DG LED bar graph.

- **Damping Algorithm**

Features a proprietary user adjustable damping algorithm for emulation of fluid damped or springs loaded gauges for smooth realistic pointer movement.

- **Gear Indicator Display**

Supports a BCD output capable of driving industry standard decoders (7447/7449) and the SD9 alphanumeric display.

- **Rev Limit Indicator**

Shift light output capable of driving up to 25mA @ 5V.

- **20x4 LCD**

20x4 character based LCD for displaying various telemetry data.

- **Short Circuit Protection**

Monitoring circuitry prevents component damage.

- **Software Configurable Operation**

Device features can be customized through a simple to use configuration utility.

- **Flash Loader Mode**

Incorporates a Flash Loader for easy firmware update via USB.

Introduction

The NITRO-SLG USB module is a standalone version of the NITRO expansion card featuring 10-bit resolution on all SPI channels and software configurable. Through various parameters, many aspects of the device can be controlled, adjusted, activated or deactivated to meet individual needs. In each case the NITRO unit will reconfigure itself without the need to re-enumerate. As such, the configuration settings can be altered at any time during normal operation without the need to disconnect the device from the USB bus.

Driver installation is automatic and most OS will install the required drivers without any user intervention. Note: Reset jumper JP1 should be removed prior to plugging the device into a USB port.

Flash Loader Mode : JP1

The NITRO-SLG USB module consists of 2 devices in 1. In Flash Loader mode, the module enumerates as a HID device used solely for updating the core firmware via USB. In Device mode the NITRO-SLG unit operates as a HID output device.

RESET Jumper JP1

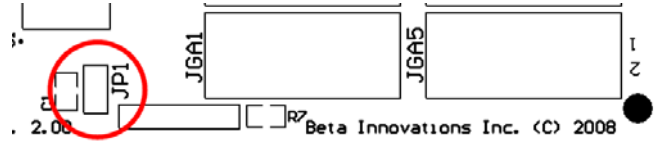

Flash Loader mode enabled



Flash Loader mode disabled (default)

RESET jumper JP1 can be used to restart the device in Flash Loader mode should the module fail to function after an update. It should remain open (disable) for normal device operation. The device can be set in Flash Loader mode when needed in order to update the core NITRO-SLG firmware. The jumper must be removed after successful firmware update prior to rebooting the device. See the Device Manager utility user manual for details on firmware update procedures.

Connecting a Gear Indicator Display

If you have purchased an SD9 display, simply plug it into the SD9 port on the NITRO-SLG module using a keyed ribbon cable. For standard 7-segment displays, use the following pinout:

3	JGÂ4	LCD	SD9	
Display BCD C	10	9	Display BCD D	
Display BCD A	8	7	Display BCD B	
NC	6	5	NC	
NC	4	3	NC	
VCC	2	1	GND	
Z	IGÂR		2	

When used with a non-alphanumeric display, shifter positions will be indicated as "1" through "9" with Neutral being displayed as "0" and Reverse as a blank output. These outputs can be used to drive a 7-segment display through any standard BCD-TO-SEVEN SEGMENT decoder driver chip as illustrated below.

Common Cathode Display

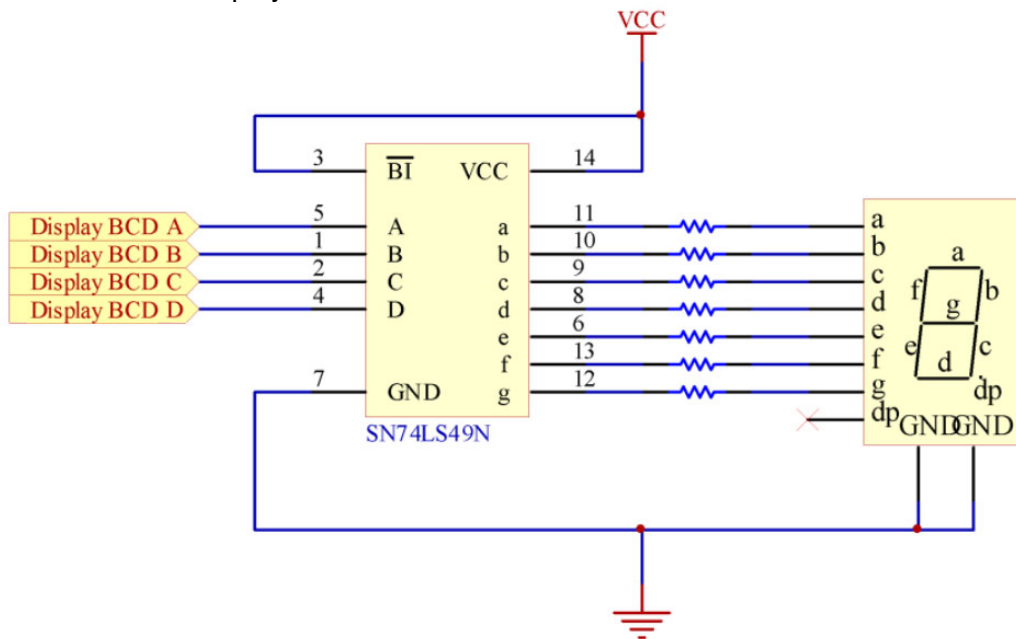

Common Anode Display

The schematic above uses a Common Cathode display with a 7449 decoder IC. Alternately, a 7447 IC can be used with Common Anode displays.

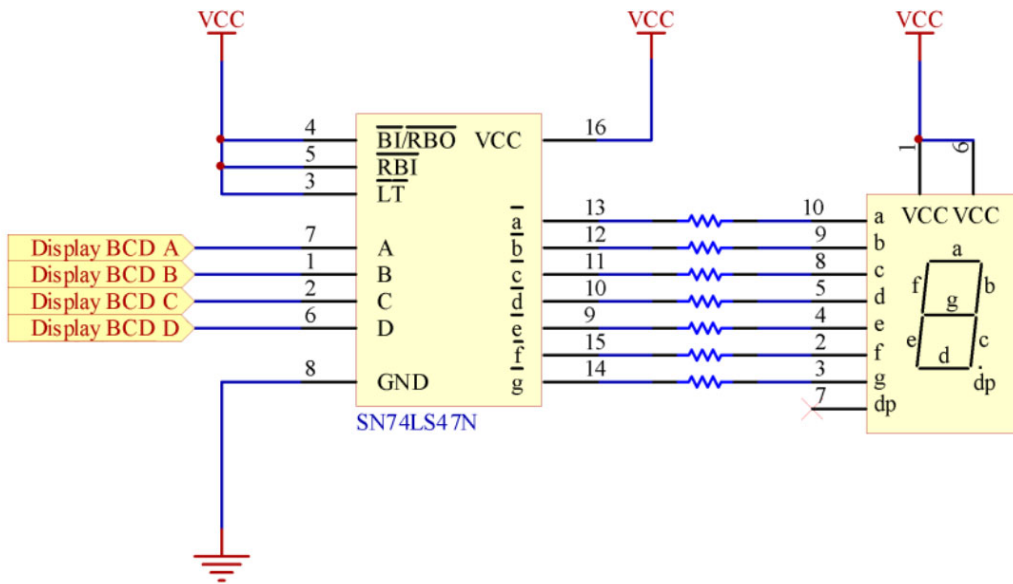

Connecting an LCD Display

If you have purchased an LCD, simply plug it into the *LCD* port on the Nitro-SLG card using the keyed ribbon cable supplied. For standard 20x4 LCD displays, use the following pinout:

LCD			
VB-	16	15	VB+
D7	14	13	D6
D5	12	11	D4
NC	10	9	NC
NC	8	7	NC
EN	6	5	R/W
RS	4	3	VLc
VCC	2	1	Vss

Connecting Air-Core Movements

1. Connect a suitable 12VDC @ 1A adapter (2.1mm plug) to **J1** on the NITRO-SLG module.
2. If you have purchased any of the AC360X-DG series air-core movements, plug them into any of the SPI output connectors on the Nitro-SLG module using the cables provided or use the following pinout for your connections:

If your gauge is not equipped with a backlight, PWO can be left unconnected.

Follow the air-core calibration procedures as defined in the documentation provided with your air-core movement circuits.

Calibration Procedure

The SPI provides a 0 to 1023 binary output corresponding to 0 to 360 degrees. Although the AC360X-DG driver circuit does not require any hardware calibration, the pointer must be properly installed at the zero position on the gauge prior to use.

In order to calibrate the driver circuit, use the USBDACS.exe test utility provided with the USBToolkit for the following procedure:

1. Set the output to 0V. Press the needle onto the Air-Core Movement's shaft at the minimum or zero position on the gauge.



2. Start the Device Manager utility and adjust the fluid damping level of the needle to the desired level. Refer to Device Manager help file for details.

The Air Core driver circuit is now calibrated and will not need to be adjusted unless the physical meter range is changed. Additional in software calibration may be required depending on the intended application. Refer to accompanying software help file for details.

	JGA1		JGA2
GND	10	9	PWO
NC	8	7	NC
NC	6	5	SDO
SCLK	4	3	CS
12V	2	1	VCC
	JGA5		JGA6

Connecting Shift Light Indicator

The Shift Indicator connector *SLED* can be used to connect a LED, which will under software control, turn on when the RPM limit is reached. Refer to software user manual for details on setting the RPM threshold for the LED indicator.

Connect any suitable LED through a current limiting resistor *R* to the pins on the *SLED* connector as illustrated below.

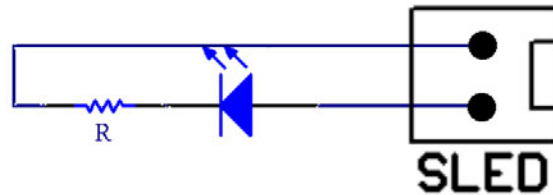
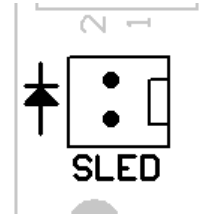

$$R = (VCC - V_{led}) / I_{led}$$

R current limiting resistor (Ohms)

VCC supply voltage (5VDC)

V_{led} Max rated LED voltage (2 - 3.4V typ.)

I_{led} Max rated LED current (15 - 25mA typ.)

IMPORTANT: DO NOT exceed 25mA current on SLED pins.

Hardware Specifications

IMPORTANT: DO NOT PLUG any peripherals into the NITRO-SLG module while the module is powered and connected to the USB port. Turn off power to the module and disconnect from the USB port before connecting any devices to the NITRO-SLG module.

Most operating systems will detect and load the appropriate HID driver for your device and do not require that a custom device driver be installed.

Maximum power consumption is 12W (@1A) and is not powered by the USB bus. You must therefore use an external power AC adapter for this device. Connect any suitable 12VDC AC adapter capable of delivering at least 1A to *J1* (2.1mm plug).

Exceeding the 500mA limit on the VCC pins will trip the short circuit protection, which will shut down all power to all ports. When this happens, the yellow PWR & blue POUT LEDs will turn off indicating a fault. The LEDs will remain off until the fault is cleared.

IMPORTANT: DO NOT CONNECT any of the NITRO-SLG VCC pins to external power supplies or voltage sources. Although common grounds can be safely connected to external grounds, it is not recommended and should be avoided whenever possible. Doing so may adversely affect performance, possibly causing strange or erratic behavior under certain conditions.

Device Status LEDs

RX	TX	POUT	PWR	Description
● Off	● Off	● Off	● Off	Fault detected or not enumerated.
● On	● On			Device enumerated.
●● Flashing	●● Flashing			Device in Suspend state.
● On	●● Flashing			Transmitting data to USB host.
●● Flashing	● On			Receiving data from USB host.
		● On	● On	5V & 12V Power On.

Mechanical Specifications

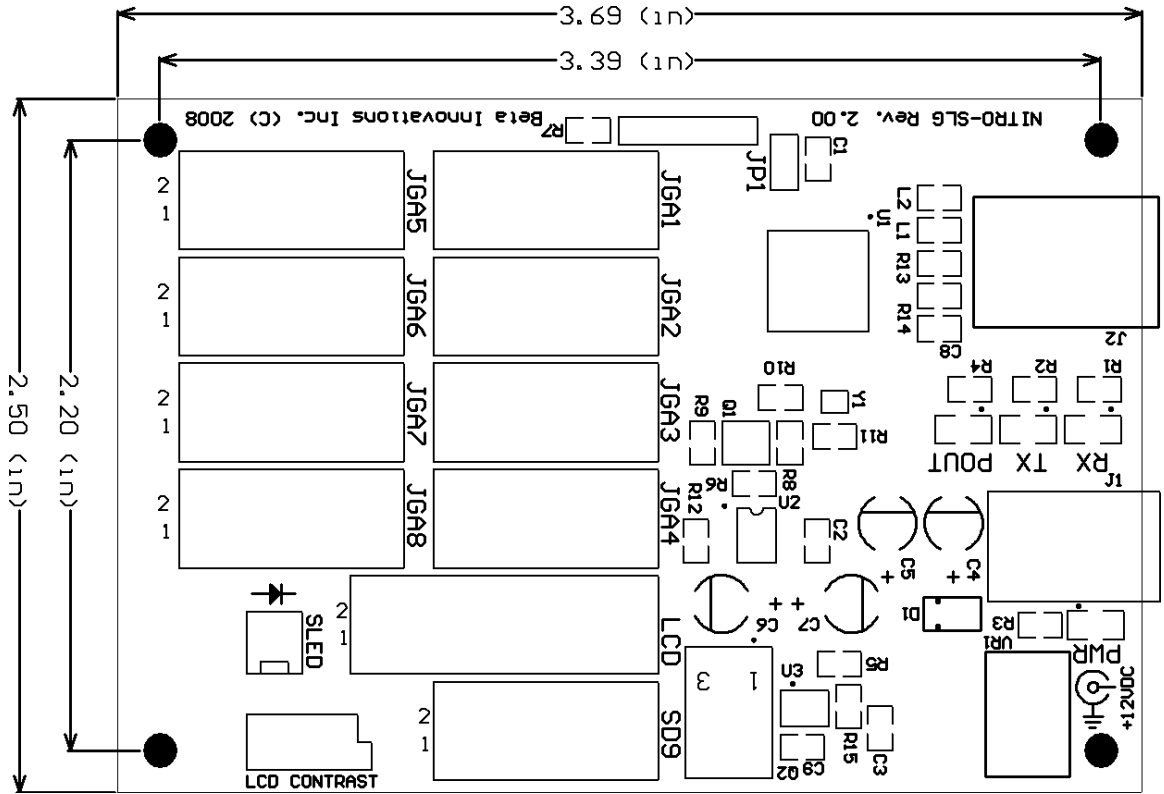

Visit www.betainnovations.com for the availability of expansion modules and accessories.