

Plasma-MM2 USB Module

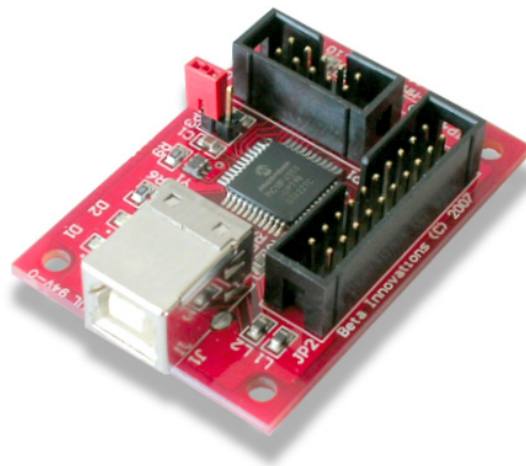

Product ID. : 920
Board Rev. : 1.10
Date : July 11, 2008
Firmware Rev. : 1.23

Table of Contents

Plasma-MM2 USB Module 4

Main Features 5

Introduction 6

Flash Loader Mode : JP3..... 7

 RESET Jumper JP3 7

Plasma-MM2 Button Structure 8

 Buttons Structure 8

 Direct Mode 8

 8x8 Scan Matrix Mode 8

Plasma-MM2 Pin-Out 9

 JP1: Analog Port Inputs 9

 Simplified Wiring 9

 Connecting Hall-Effect Sensors to Analog Inputs 10

 Connecting Linear Transducers to Analog Inputs 10

 Connecting Analog Joystick Pots 11

 JP2: Direct Mode Digital Port Inputs 12

 Simplified Wiring 12

 SPST Toggle Switches (On-Off)..... 12

 SPDT Switches (On-On) 13

 Rocker Switches (On-Off-On)..... 13

 Push Button Switches..... 13

 Illuminated Rocker Switches 13

 Multi-Position Rotary Switches 14

 Connecting Digital POV HATS 14

 Rotary Mode Inputs 15

 JP2: Scan Matrix Mode Digital Port Inputs 16

 Scan Matrix Wiring..... 16

 Connecting Rotary Encoders..... 17

Hardware Specifications	18
Device Status LEDs	18
Mechanical Specifications	19

Plasma-MM2 USB Module

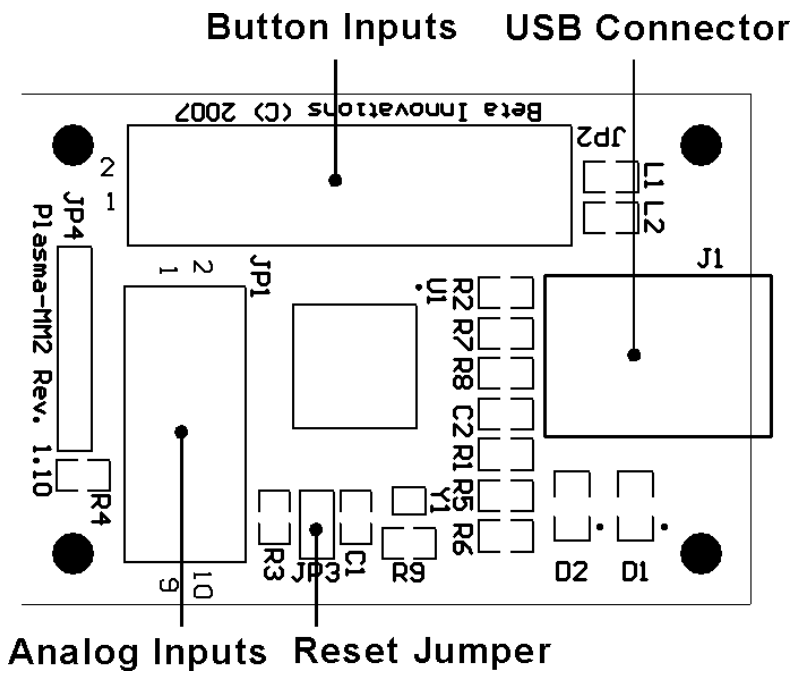
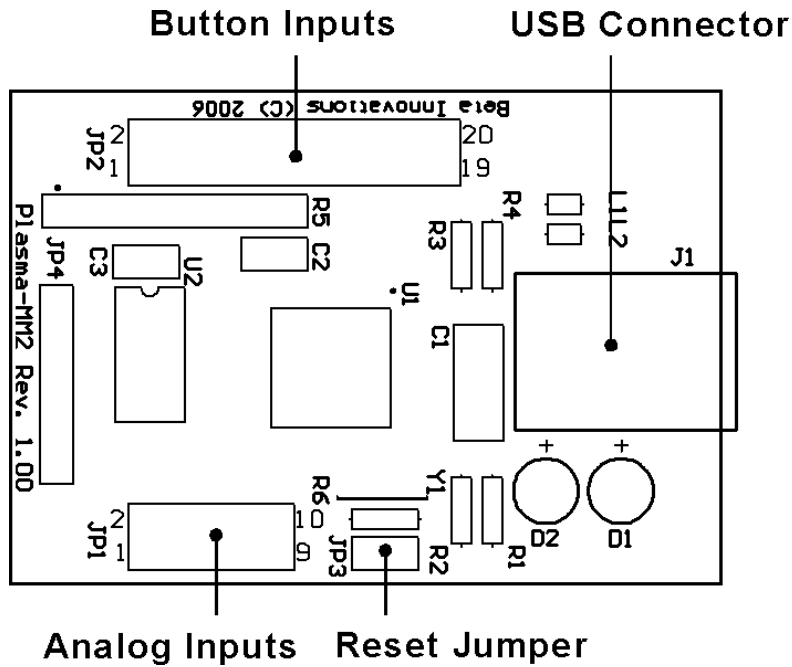

Main Features

- **Easy installation**
The Plasma-MM2 device is a Full Speed USB HID compliant device, which employs default drivers supplied by most OS and powered by the USB Bus.
- **Analog Axis Input**
Supports a variety of input devices including, Potentiometers, Hall-Effect sensors, and pressure transducers or force sensors for precise control.
- **Filtering Algorithm**
Features a proprietary user adjustable 2 level *Recursive Moving Delta Sigma* filtering algorithm virtually eliminating noise, spike and jitter for stable output.
- **Hardware Calibration**
All axis channel calibration data is stored onboard eliminating the need for calibration in Windows. Additionally, axis channels can be tweaked for optimal performance as needed by setting trim zones.
- **Axis Resolutions**
Up to 12-bits (4095 steps) axis resolution on analog channels.
- **POV HAT Support**
2 Digital 8-way POV HAT inputs.
- **Button Inputs**
Up to 16 inputs in direct mode (Active Low) and up to 64 inputs in scan matrix mode (organized as 8 x 8) compatible with any kind of switch: toggle, push button, etc. The first 16 inputs are individually configurable for various modes of operation.
- **Software Configurable Operation**
Device features can be customized through a simple to use configuration utility.
- **Flash Loader Mode**
Incorporates a Flash Loader for easy firmware update via USB.

Introduction

The Plasma-MM2 USB adapter is the next generation input device now featuring 12-bit resolution on analog channels and software configurable. Through various parameters, many aspects of the device can be controlled, adjusted, activated or deactivated to meet individual needs. In each case the Plasma unit will reconfigure itself without the need to re-enumerate. As such, the configuration settings can be altered at any time during normal operation without the need to disconnect the device from the USB bus.

Driver installation is automatic and most OS will install the required drivers without any user intervention. Note: Reset jumper JP3 should be removed prior to plugging the device into a USB port.

Flash Loader Mode : JP3

The Plasma-MM2 USB adapter consists of 2 devices in 1. In Flash Loader mode, the module enumerates as a non-joystick device used solely for updating the core firmware via USB. In Device mode the Plasma unit operates as a standard DirectX compatible joystick device.

RESET Jumper JP3

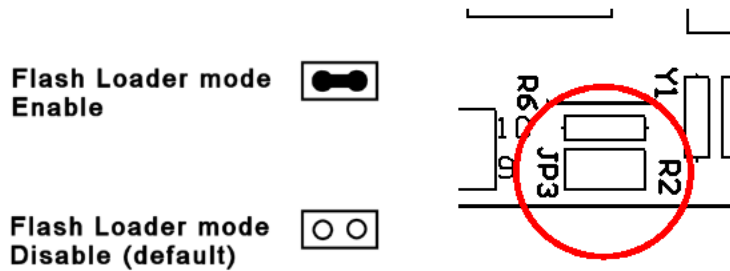

RESET jumper JP3 can be used to restart the device in Flash Loader mode. It should remain open (disable) for normal device operation. The device can be set in Flash Loader mode when needed in order to update the core Plasma-MM2 firmware. The jumper must be removed after successful firmware update prior to rebooting the device. See the Device Manager utility user manual for details on firmware update procedures.

Plasma-MM2 Button Structure

Buttons Structure

Direct Mode

Digital Channel	1	2	3	4	5	6	7	8
HAT Digital Mode	9	10	11	12	13	14	15	16

8x8 Scan Matrix Mode

8x8 Scan Matrix	1	2	3	4	5	6	7	8
HAT Digital Mode	9	10	11	12	13	14	15	16
	17	18	19	20	21	22	23	24
	25	26	27	28	29	30	31	32
	33	34	35	36	37	38	39	40
	41	42	43	44	45	46	47	48
	49	50	51	52	53	54	55	56
	57	58	59	60	61	62	63	64

The structure above lists the button order as seen by applications running on systems supporting USB HID compliant devices. Note that not all OS drivers are capable of reading all inputs. Legacy Windows drivers will only support the first 32 buttons including the Game Controllers applet found in the Control Panel. However, DirectX drivers and any software that uses DirectX Direct Input can support up to 128 buttons per device. There are no limits for Beta Innovations custom drivers, which as of this writing support up to 256 inputs per device.

When configured in Digital Mode, POV HAT inputs will be directed to inputs 9 to 12 for HAT channel 1 and inputs 13 to 16 for HAT channel 2. These inputs will remain inactive when HAT channels are configured for use as POV HATs.

Plasma-MM2 Pin-Out

JP1: Analog Port Inputs

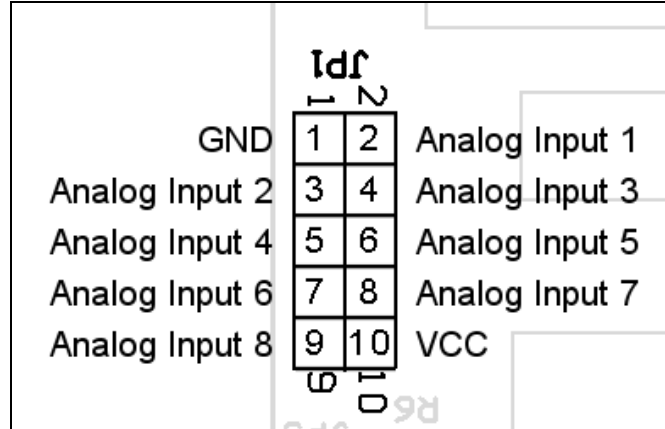

Default Analog Axis Inputs

- Analog Input 1: X-Axis
- Analog Input 2: Y-Axis
- Analog Input 3: Z-Axis
- Analog Input 4: X-Rotation
- Analog Input 5: Y-Rotation
- Analog Input 6: Z-Rotation
- Analog Input 7: Slider 1
- Analog Input 8: Slider 2

NOTE: Some operating system's default USB drivers may not support 8 axes. MS Windows 98 (USB Upgrade) / ME / 2000 / XP / Vista support up to 8 axis per device.

Simplified Wiring

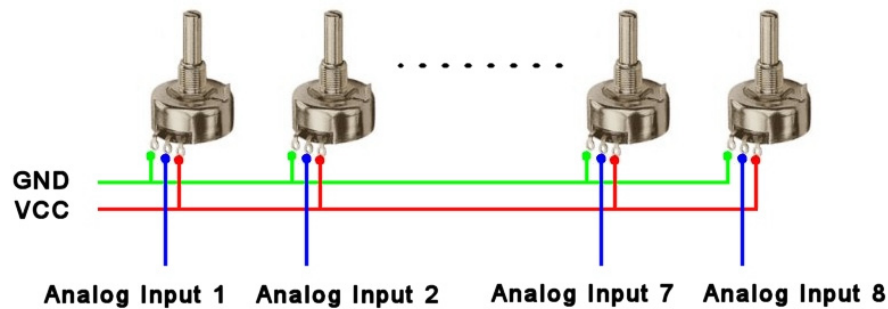

Connecting Potentiometers to Analog Inputs

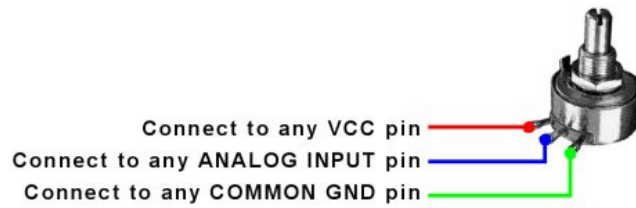

Connecting Hall-Effect Sensors to Analog Inputs

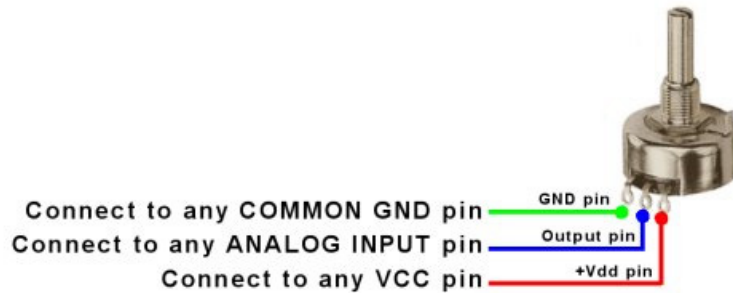

A low pass filter may be required on the output of some Hall-Effect Sensors due to mismatch conditions with the input impedance of the ADC's sampling circuitry and/or noise from the Hall-Effect Sensor amplifier circuit.

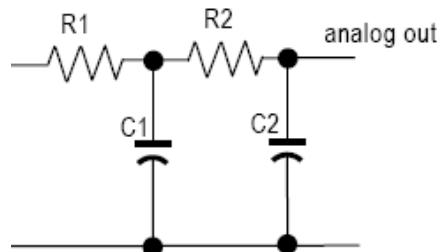

Component values are dependant on the frequency of the output signal noise.

Connecting Linear Transducers to Analog Inputs



Connecting Analog Joystick Pots

NOTE: Conventional analog Joystick potentiometers have one unconnected pin on axis pots. It is imperative that this pin be grounded in order to properly function when connected to the Plasma analog port inputs.

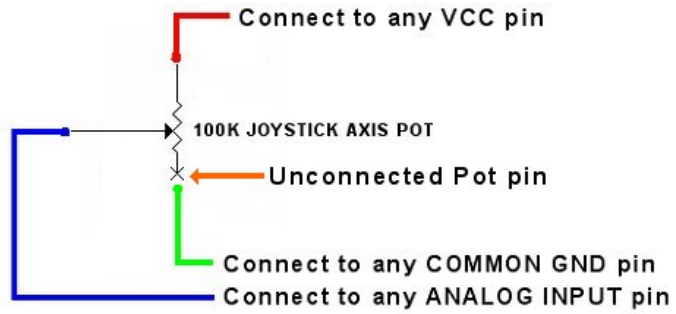

JP2: Direct Mode Digital Port Inputs

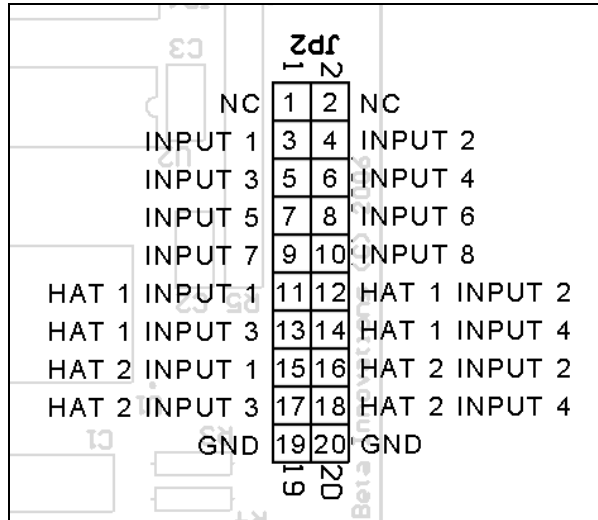

All inputs are active low, which means you must ground an input in order to register a high “ON” signal at the output.

Simplified Wiring

In direct mode, the Plasma module does not use a scan matrix type of input layout. In addition to simplifying wiring considerably, diodes are not required and inputs will not suffer from ghost signals when activating several switches at the same time.

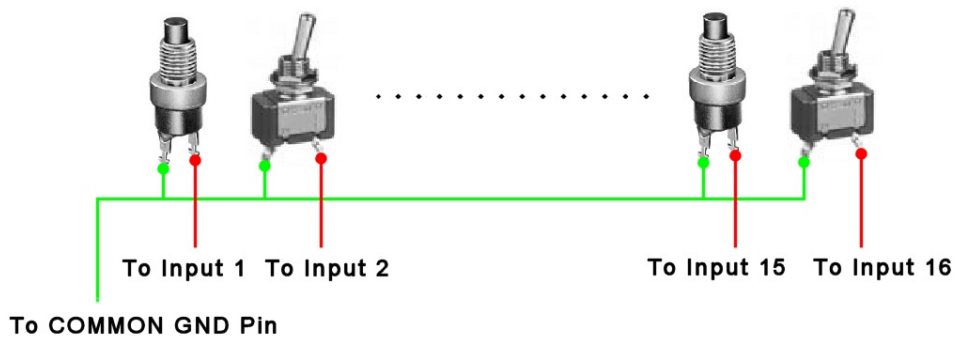

SPST Toggle Switches (On-Off)

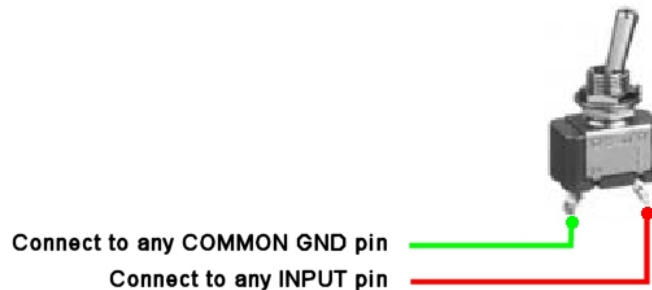

Beta Innovations Inc.

SPDT Switches (On-On)

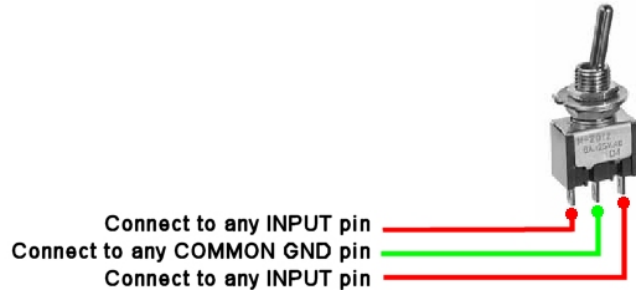

Rocker Switches (On-Off-On)

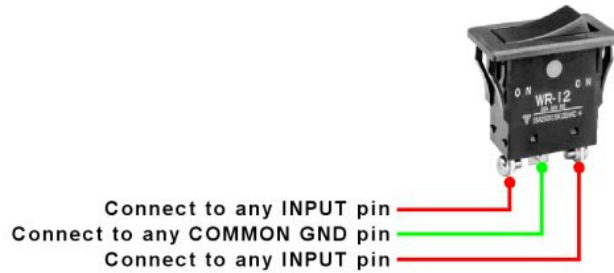

Push Button Switches

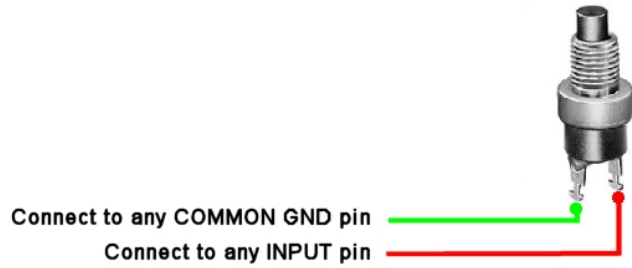

Illuminated Rocker Switches

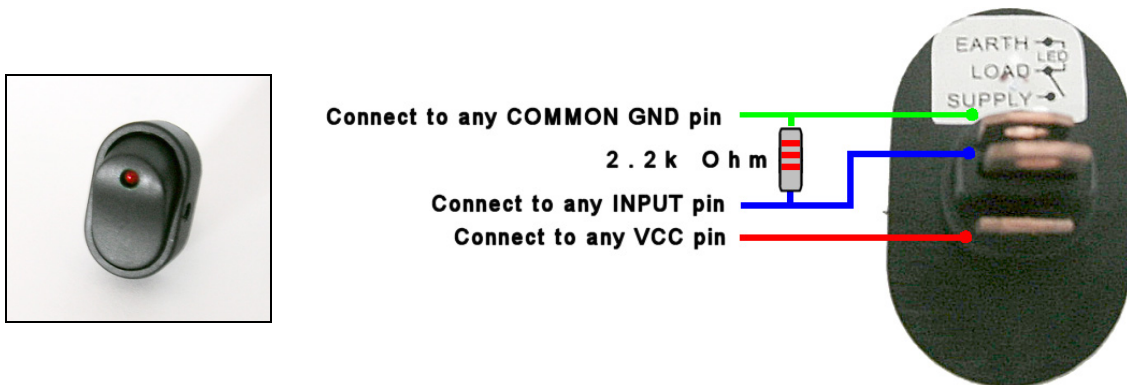

Note: by using this configuration, check *Invert* mode for the input in the device manager utility.

Multi-Position Rotary Switches

Multi-Position Rotary Switches come in many configurations, but the most important thing to note is that they all share one or several common pins. These common pins must be connected to any one of the common GND pins found on the Plasma unit. All other pins can be connected to any one of the inputs as required.

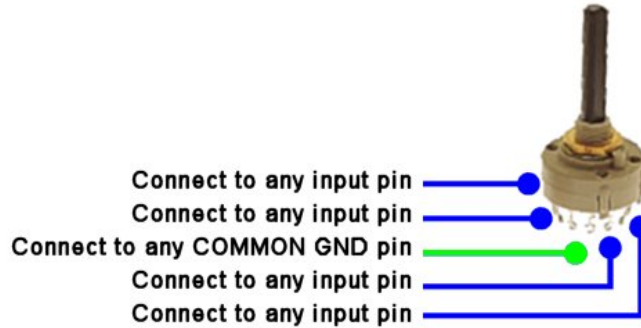

Connecting Digital POV HATS

When the POV HAT port is configured in Digital Mode, standard switches can be connected for 8 additional button inputs.

- HAT input 1: POV SWITCH UP
- HAT input 2: POV SWITCH RIGHT
- HAT input 3: POV SWITCH DOWN
- HAT input 4: POV SWITCH LEFT

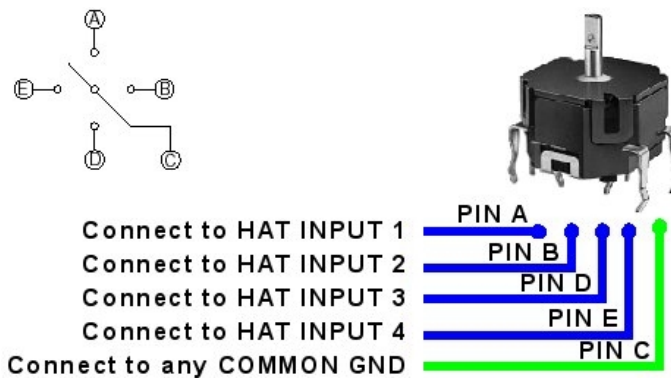

The POV HAT switch common pin must be connected to one of the ground pins. All other HAT switch pins must be connected to the appropriate input pins as describe above.

Rotary Mode Inputs

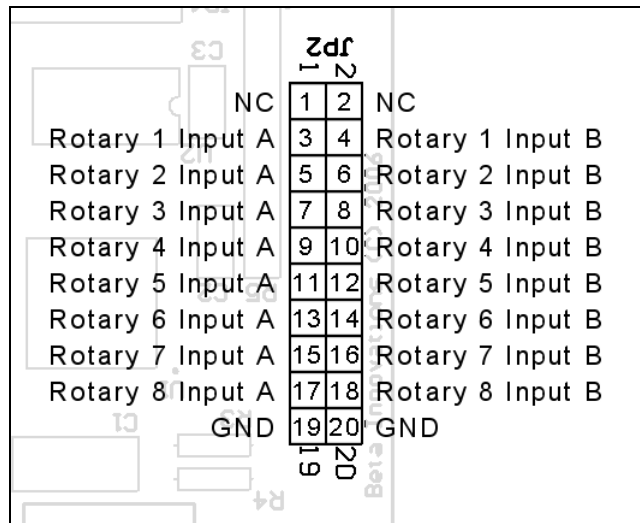

When pairs of digital Inputs are configured for Rotary Mode, standard rotaries can be connected to the inputs for decoding without the need for external decoding circuitry. A maximum of 8 rotaries can be connected to input pairs. Note that not all inputs need to be configured for rotary support.

Current firmware revision supports 3 types of phase shifted encoding as illustrated below.

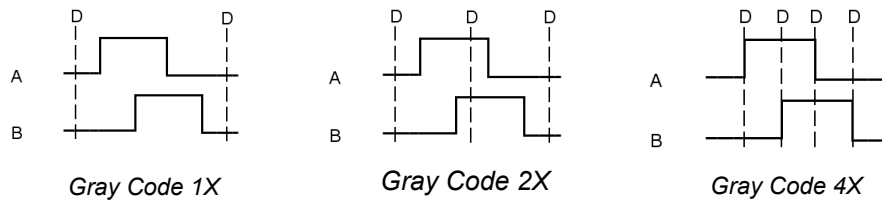

Decoding method depends largely on how the physical detents are implemented on the rotary with respect to output pulses. Rotary encoders that do not have any detents “D” can employ any of the above methods with up to 4X multiplier on output pulses.

Gray code 1X: provides a 1:1 decoding of phased pulses. Each input pulse results in a single output pulse.

Gray Code 2X: provides a 1:2 decoding of phased pulses. Each input pulse results in 2 output pulses.

Gray Code 4X: provides a 1:4 decoding of phased pulses. Each inputs pulse results in 4 output pulses.

Typical rotaries consist of 3 pins. Pin “A” & “B” are the encoded outputs and one common middle pin “C”. Refer to manufacturer’s specifications for exact pin out.

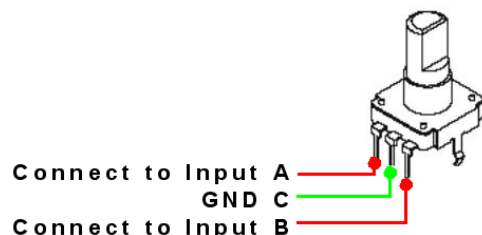

JP2: Scan Matrix Mode Digital Port Inputs

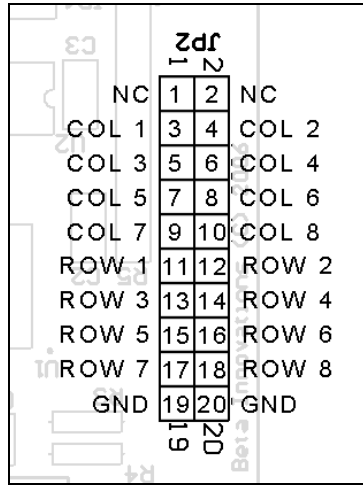

Scan Matrix Wiring

In scan matrix mode, the Plasma module will organize the inputs in 8 x 8 fashion (8 rows by 8 columns). GND pins must not be used in this mode in order to avoid shorting the matrix pins.

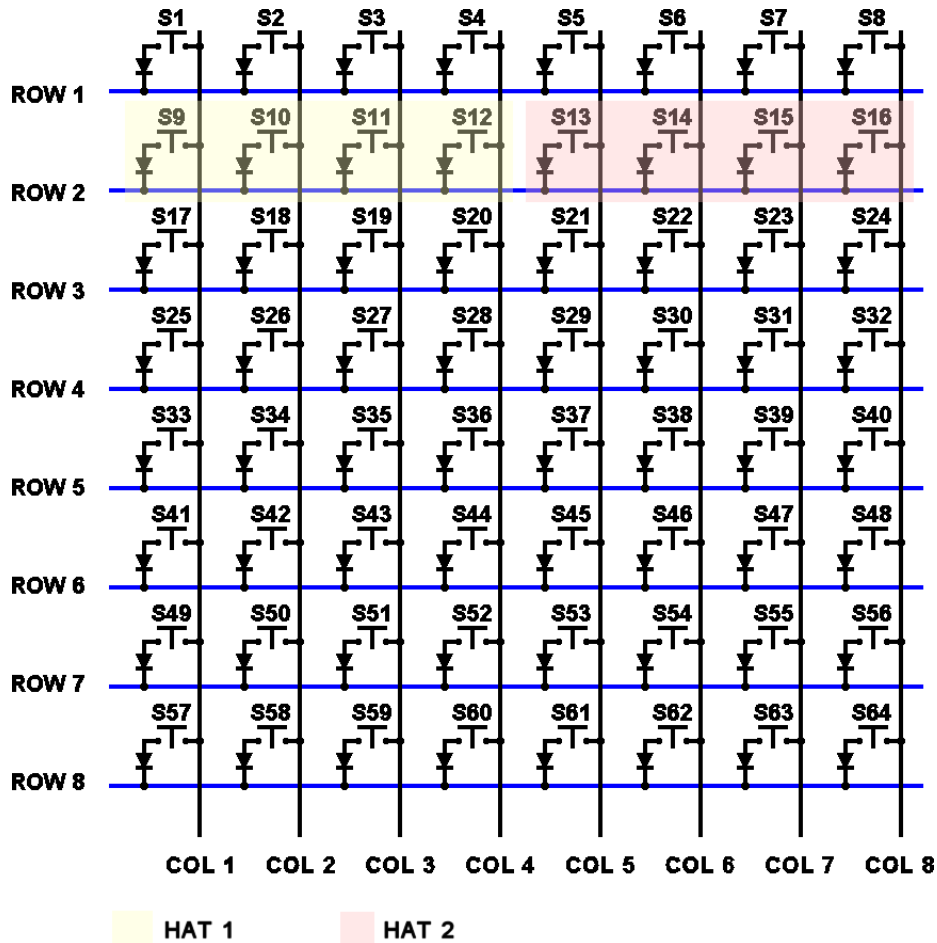

Connecting Rotary Encoders

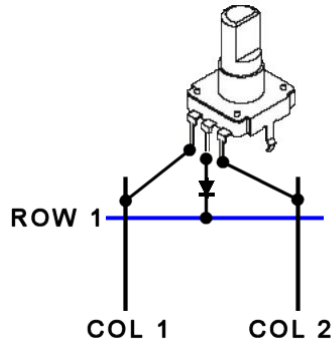

IMPORTANT: When activating Scan Matrix mode, disconnect all switches wired to ground pins in order to avoid short circuit conditions, possibly causing permanent damage to the Plasma module input pins. No grounds should be connected to any of the pins in this mode.

POV HAT inputs are show highlighted. HAT 1 inputs are located on S9 to S12 and HAT 2 inputs are located on S13 to S16. If set to digital mode, the HAT inputs will appear as inputs 9 through 16.

IMPORTANT: HAT switches connected to a scan matrix cannot use a common shared pin connected to GND as this would cause a short circuit. Only HATs comprised of 4 separate switches can be safely connected to the scan matrix.

In order to avoid ghosting (false inputs signals), diodes are required if using toggle switches or if multiple switches are turned on at the same time. Any suitable rectifier diode may be used such as the 1N4148. These can be eliminated if only momentary switches are used and only one switch is pressed at a time.

Hardware Specifications

Most operating systems will detect and load the appropriate HID driver for your device and do not require that a custom device driver be installed. These default drivers may not support all features of the Plasma-MM2 module on some operating systems.

Maximum power consumption is 500mW (100mA) and is powered by the USB bus. You do not need to use an external power supply for this device.

Potentiometer values are not critical for the proper operation of analog inputs, but values should not be less than 5K Ohm and not greater than 1Meg Ohm for optimal operation. Keep the wiring tidy and as short as possible. Do not twist pot wires. Use untwisted shielded cabling or a flat ribbon cable.

In order to avoid potential damage to the analog inputs, pots should be connected to the port with the power turned off by disconnecting the unit from the USB bus.

NOTE: DO NOT CONNECT any of the Plasma-MM2 VCC pins to external power supplies or voltage sources. Although common grounds can be safely connected to external grounds, it is not recommended and should be avoided whenever possible. Doing so may adversely affect performance, possibly causing strange or erratic behavior under certain conditions.

Device Status LEDs

D1	D2	Description
● Off	● Off	Device not powered or not enumerated.
● On	● On	Device enumerated in Flash Loader mode.
● On	● Off	Device enumerated in standard Device mode.
●● Flashing	●● Flashing	Device in Suspend state.
● On	●● Flashing	Transmitting data to USB host (Flash Loader Mode).
●● Flashing	● On	Receiving data from USB host (Flash Loader Mode).
● On	●● Flashing	Transmitting data to USB host (Device Mode).
●● Flashing	●● Flashing	Receiving data from USB host (Device Mode).

Mechanical Specifications

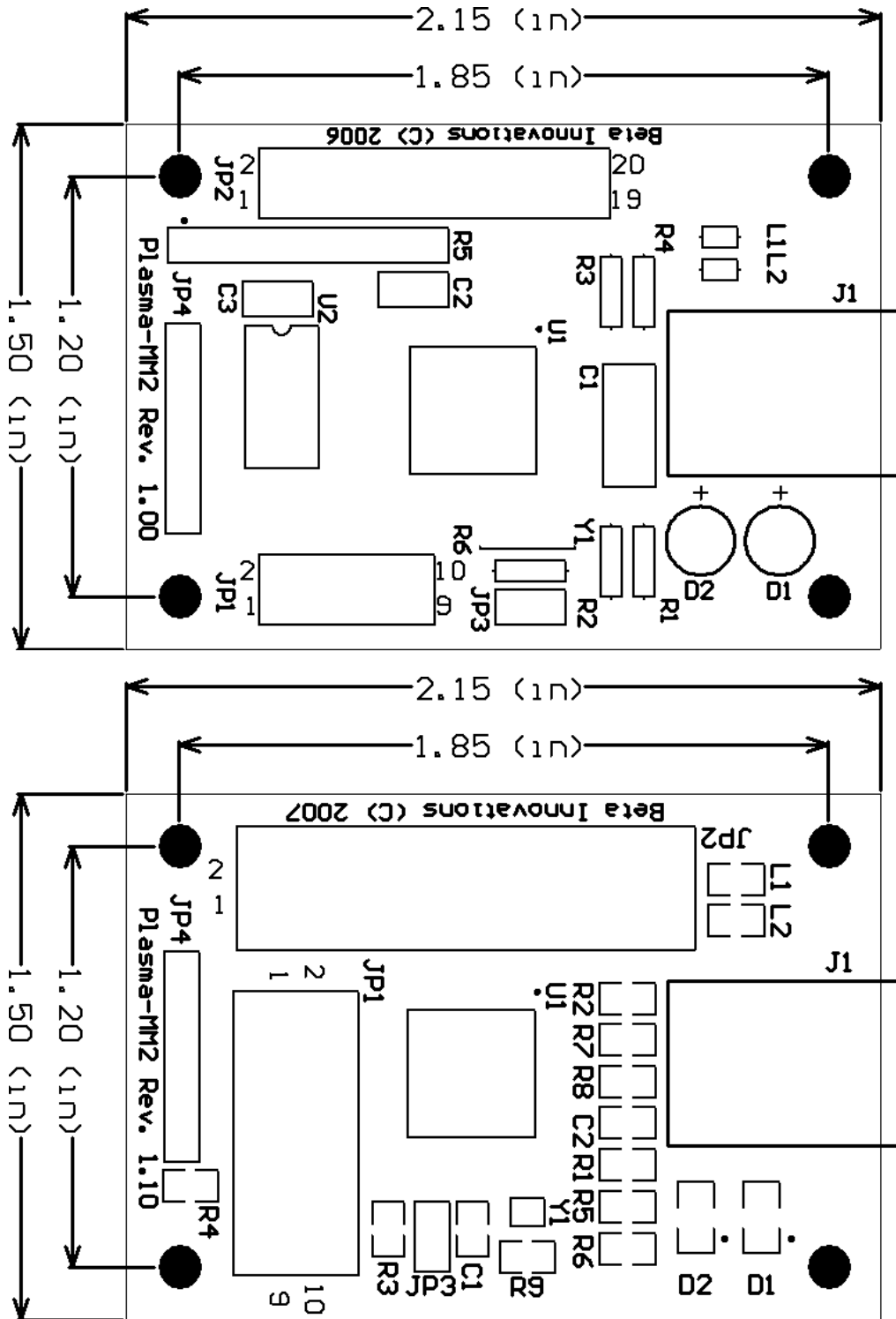

Visit www.betainnovations.com for the availability of expansion modules and accessories.